

# Air/ Hydraulic Cylinders

- **SERIES "A"**

250 PSI AIR  
1½" to 14" BORES

- **SERIES "L"**

MEDIUM PRESSURE HYDRAULIC  
1½" to 14" BORES

*Manufactured By:*



77684 Hwy 99 South, Cottage Grove, OR, USA 97424  
www.Kimwood.com Phone: (800) 942-4401



# SELECTING A ROD END

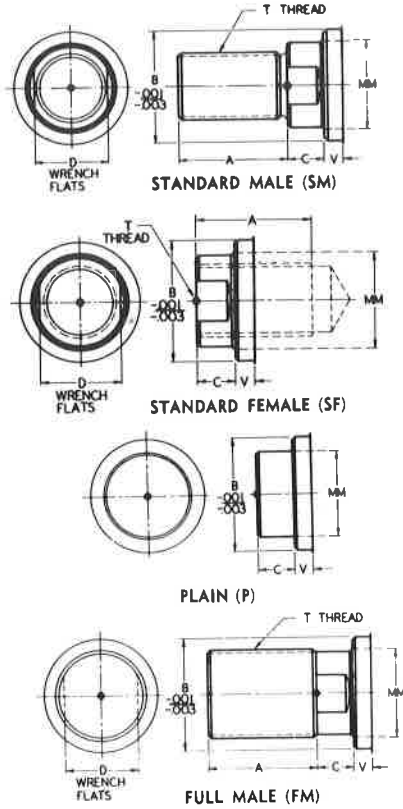

BORE	ROD NO.	MM	A	B +0.000 -0.002	C	D	V	ROD THREAD - T			
								SM SF	FM	N	
1 1/2	1 (STD.)	5/8	3/4	1.125	3/8	1/2	1/4	7/16 - 20	5/8 - 18		
	2	1	1 1/8	1.500	1/2	7/8	1/2	3/4 - 16	1 - 14	3/8	
2	1 (STD.)	9/8	3/4	1.125	3/8	1/2	1/4	7/8 - 20	5/8 - 18		
	2	1	1 1/8	1.500	1/2	7/8	1/2	3/4 - 16	1 - 14	3/8	
	3	1 3/4	1 5/8	2.000	5/8	1 1/4	3/8	1 - 14	1 3/8 - 12	5/8	
2 1/2	1 (STD.)	9/8	3/4	1.125	3/8	1/2	1/4	7/8 - 20	5/8 - 18		
	2	1	1 1/8	1.500	1/2	7/8	1/2	3/4 - 16	1 - 14	3/8	
	3	1 3/8	1 5/8	2.000	5/8	1 1/4	3/8	1 - 14	1 3/8 - 12	5/8	
	4	1 3/4	2	2.375	3/4	1 1/2	3/4	1 1/4 - 12	1 3/4 - 12	7/8	
3 1/4	2 (STD.)	1	1 1/8	1.500	1/2	7/8	1/4	3/4 - 16	1 - 14		
	3	1 3/8	1 5/8	2.000	5/8	1 1/4	3/8	1 - 14	1 3/8 - 12	1/4	
	4	1 3/4	2	2.375	3/4	1 1/2	1/2	1 1/4 - 12	1 3/4 - 12	1/2	
4	2 (STD.)	1	1 1/8	1.500	1/2	7/8	1/4	3/4 - 16	1 - 14		
	3	1 3/8	1 5/8	2.000	5/8	1 1/4	3/8	1 - 14	1 3/8 - 12	1/4	
	4	1 3/4	2	2.375	3/4	1 1/2	1/2	1 1/4 - 12	1 3/4 - 12	1/2	
	5	2	2 1/4	2.625	7/8	1 3/4	1/2	1 1/2 - 12	2 - 12	5/8	
	6	2 1/2	3	3.125	1	2 1/4	1/2	1 1/2 - 12	2 1/2 - 12	3/4	
5	2 (STD.)	1	1 1/8	1.500	1/2	7/8	1/4	3/4 - 16	1 - 14		
	3	1 3/8	1 5/8	2.000	5/8	1 1/4	3/8	1 - 14	1 3/8 - 12	1/4	
	4	1 3/4	2	2.375	3/4	1 1/2	1/2	1 1/4 - 12	1 3/4 - 12	1/2	
	5	2	2 1/4	2.625	7/8	1 3/4	1/2	1 1/2 - 12	2 - 12	5/8	
	6	2 1/2	3	3.125	1	2 1/4	1/2	1 1/2 - 12	2 1/2 - 12	3/4	
	7	3 (STD.)	1 3/8	1 5/8	2.000	5/8	1 1/4	1/4	1 - 14	1 3/8 - 12	
6	4	1 3/4	2	2.375	3/4	1 1/2	3/8	1 1/4 - 12	1 3/4 - 12	1/4	
	5	2	2 1/4	2.625	7/8	1 3/4	3/8	1 1/2 - 12	2 - 12	3/8	
	6	2 1/2	3	3.125	1	2 1/4	1/2	1 1/2 - 12	2 1/2 - 12	5/8	
7	3 (STD.)	1 3/8	1 5/8	2.000	5/8	1 1/4	1/4	1 - 14	1 3/8 - 12		
	4	1 3/4	2	2.375	3/4	1 1/2	3/8	1 1/4 - 12	1 3/4 - 12	1/4	
	5	2	2 1/4	2.625	7/8	1 3/4	3/8	1 1/2 - 12	2 - 12	3/8	
	6	2 1/2	3	3.125	1	2 1/4	1/2	1 1/2 - 12	2 1/2 - 12	5/8	
	7	3 (STD.)	1 3/8	1 5/8	2.000	5/8	1 1/4	1/4	1 - 14	1 3/8 - 12	
	8	1 3/4	2	2.375	3/4	1 1/2	3/8	1 1/4 - 12	1 3/4 - 12	1/4	
8	5	2	2 1/4	2.625	7/8	1 3/4	3/8	1 1/2 - 12	2 - 12	3/8	
	6	2 1/2	3	3.125	1	2 1/4	1/2	1 1/2 - 12	2 1/2 - 12	5/8	
	7	3	3 1/2	3.750	1	2 3/4	1/2	2 1/4 - 12	3 - 12	3/4	
10	4 (STD.)	1 3/8	2	2.375	3/4	1 1/2	3/8	1 1/4 - 12	1 3/4 - 12	1/4	
	5	2	2 1/4	2.625	7/8	1 3/4	3/8	1 1/2 - 12	2 - 12	3/8	
	6	2 1/2	3	3.125	1	2 1/4	1/2	1 1/2 - 12	2 1/2 - 12	5/8	
	7	3	3 1/2	3.750	1	2 3/4	1/2	2 1/4 - 12	3 - 12	3/4	
	8	3 1/2	3 1/2	4.250	1	3 1/4	1/2	2 1/2 - 12	3 1/2 - 12	3/4	
	9	4	4	4.750	1	3 3/4	1/2	3 - 12	4 - 12	1 1/4	
12	5 (STD.)	2	2 1/4	2.625	7/8	1 3/4	3/8	1 1/2 - 12	2 - 12		
	6	2 1/2	3	3.125	1	2 1/4	1/2	1 1/2 - 12	2 1/2 - 12	1/4	
	7	3	3 1/2	3.750	1	2 3/4	1/2	2 1/4 - 12	3 - 12	1/4	
	8	3 1/2	3 1/2	4.250	1	3 1/4	1/2	2 1/2 - 12	3 1/2 - 12	1/4	
	9	4	4	4.750	1	3 3/4	1/2	3 - 12	4 - 12	1/4	
	10	5 (STD.)	2 1/2	3	3.125	1	2 1/4	1/2	1 1/2 - 12	2 1/2 - 12	
14	7	3	3 1/2	3.750	1	2 3/4	1/2	2 1/4 - 12	3 - 12		
	8	3 1/2	3 1/2	4.250	1	3 1/4	1/2	2 1/2 - 12	3 1/2 - 12		
	9	4	4	4.750	1	3 3/4	1/2	3 - 12	4 - 12		
	10	4 1/2	4 1/2	5.250	1	4 1/4	1/2	3 1/4 - 12	4 1/2 - 12		

# SELECTING ACCESSORIES

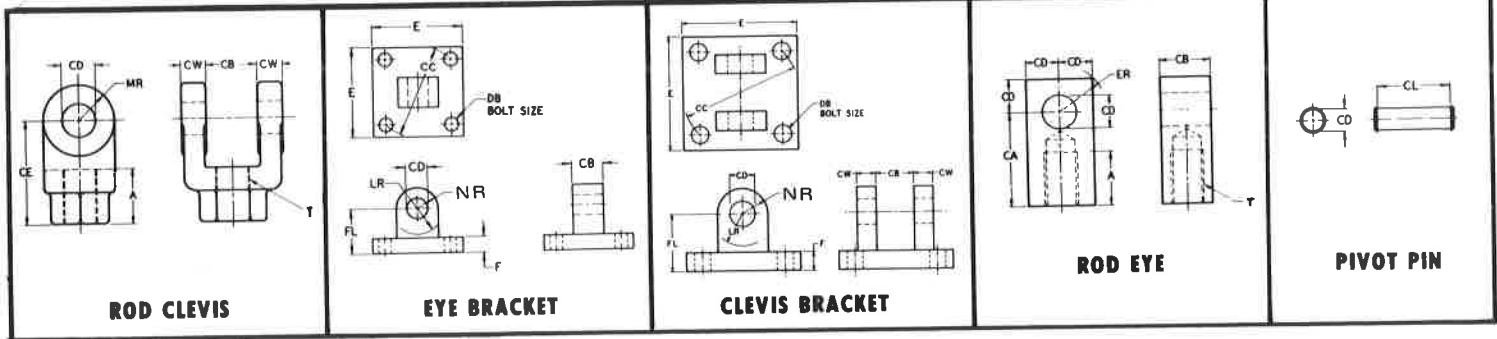

BORE SIZE	ROD CODE NO.	ROD THD. T	ACCESSORY PART NUMBERS					DIMENSIONS													
			ROD CLEVIS	ROD EYE	EYE BRACKET	CLEVIS BRACKET	PIVOT PIN	A	CA	CB	CC	CD	CE	CL	CW	E	ER	F	DB	FL	MR
1 1/2, 2, 2 1/2	1	7/16-20	C-1	F-1	W-1	X-1	R-1	3/4	1 1/2	3/4	2.3	1/2	1 1/2	1 13/16	1/2	2 1/2	1 1/16	3/8	3/8	1 1/8	1/2
3/4, 4, 5	2	3/4-16	C-2	F-2	W-2	X-2	R-2	1 1/8	2 1/8	1 1/4	3.6	3/4	2 3/8	2 5/8	5/8	3 1/2	1 1/16	3/8	1/2	1 7/8	3/4
6, 7, 8	3	1-14	C-3	F-3	W-3	X-3	R-3	1 5/8	2 13/16	1 1/2	4.6	1	3 1/8	3 1/4	3/4	4 1/2	1 7/16	3/4	5/8	2 1/4	1
10	4	1 1/4-14	C-4	F-4	W-4	X-4	R-4	2	3 1/4	2	5.4	1 3/8	4 1/8	4 1/4	1	5	1 13/16	7/8	5/8	3	1 3/8
12	5	1 1/2-12	C-5	F-5	W-5	X-5	R-5	2 1/4	4	2 1/2	7	1 3/4	4 1/2	5 1/4	1 1/4	6 1/2	2 1/2	7/8	7/8	3 1/8	1 3/4
14	6	1 7/8-12	C-6	F-6	W-6	X-6	R-6	3	5	2 1/2	8.1	2	5 1/2	5 1/8	1 1/4	7 1/2	2 13/16	1	1	3 1/2	2

# MOUNTING STYLES AND DIMENSIONS

## STYLE A

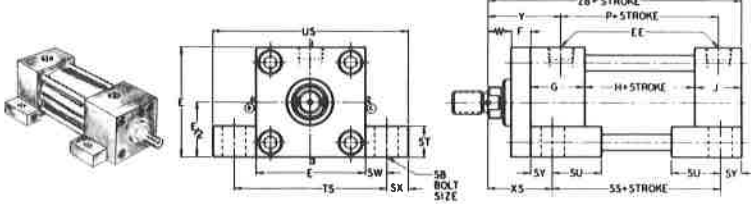

SIDE LUG MOUNTING – MOUNTING STYLE -A- NFPA MS2

## STYLE B

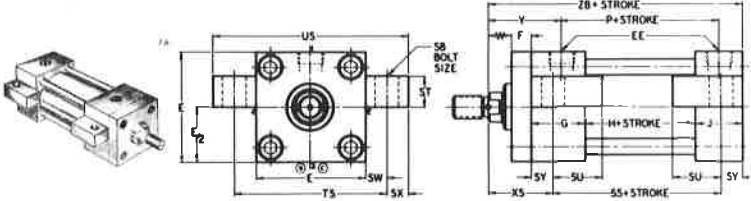

CENTER LINE LUG MOUNTING – MOUNTING STYLE -B- NFPA MS3

## STYLE C

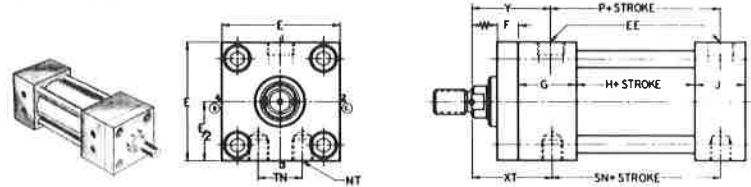

SIDE TAPPED MOUNTING MOUNTING STYLE -C- NFPA MS4

## STYLE D

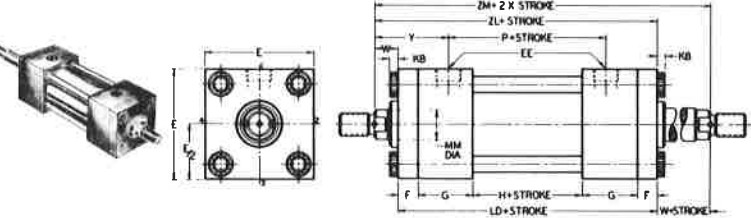

SIDE TAPPED MOUNTING – MOUNTING STYLE -D- NFPA MDS2,

## STYLE E

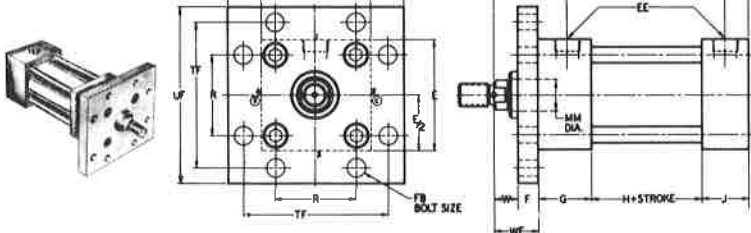

HEAD SQUARE FLANGE MOUNT – MOUNTING STYLE -E- NFPA MF5

## STYLE F

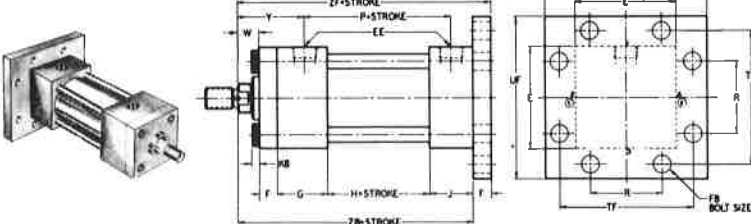

CAP SQUARE FLANGE MOUNT – MOUNTING STYLE -F- NFPA MF6

## STYLE G

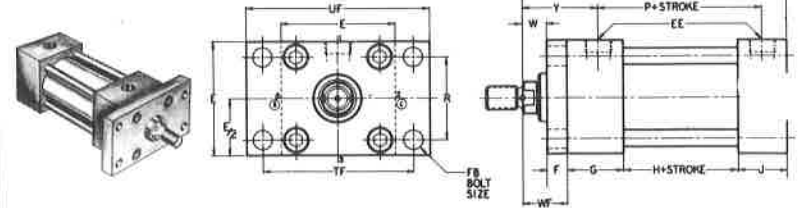

HEAD RECTANGULAR FLANGE MOUNT – MOUNTING STYLE -G- NFPA MF1

## STYLE H

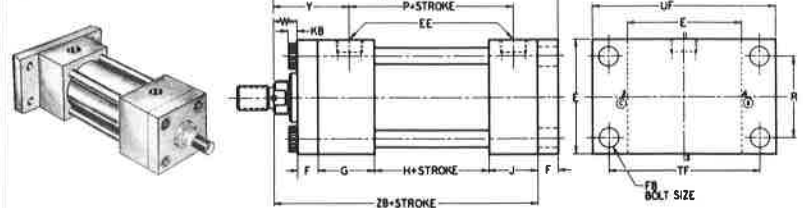

CAP RECTANGULAR FLANGE MOUNT – MOUNTING STYLE -H- NFPA MF2

## STYLE J

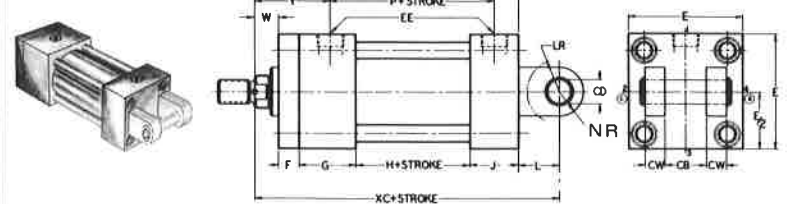

CAP FIXED CLEVIS MOUNT – MOUNTING STYLE -J- NFPA MP1

## STYLE K

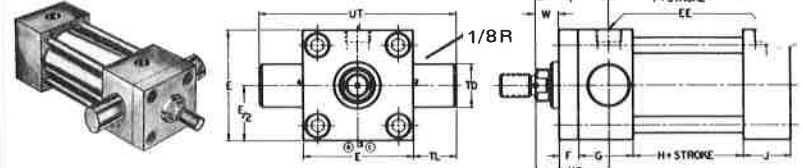

\*HEAD TRUNNION MOUNT – MOUNTING STYLE -K- NFPA MT1

## STYLE L

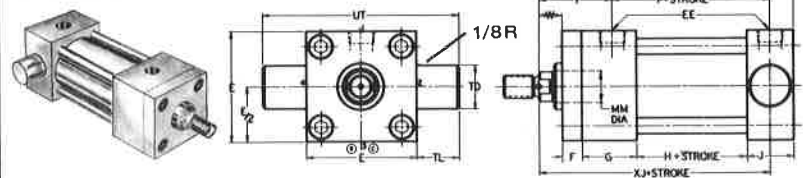

\*CAP TRUNNION MOUNT – MOUNTING STYLE -L- NFPA MT2

## STYLE M

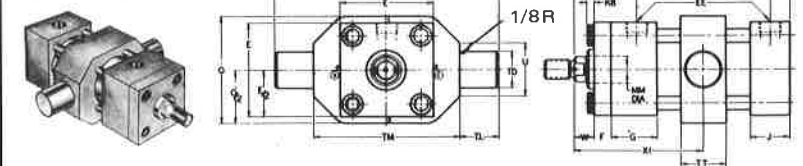

\*INTERMEDIATE FIXED TRUNNION MOUNT – STYLE -M- NFPA MT3

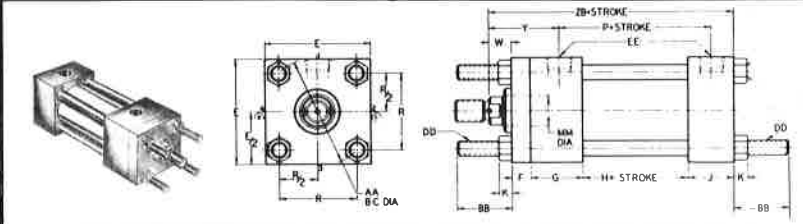

TIE ROD EXTENDED MOUNTING STYLE -O- CAP END NFPA MX2  
STYLE -N- BOTH ENDS NFPA MX1 STYLE -P- HEAD END NFPA MX3

\*Trunion pins should be subjected to shear loading only.

# SERIES "A" & "L" CYLINDER DIMENSIONS

BORE SIZE													
	1½	2	2½	3¼	4	5	6	7	8	10	12	14	
AA	2.02	2.6	3.1	3.9	4.7	5.8	6.9	8.10	9.1	11.2	13.3	15.4	AA
BB	1	1-1/8	1-1/8	1-3/8	1-3/8	1-13/16	1-13/16	2-5/16	2-5/16	2-11/16	2-11/16	3-3/16	BB
CB	¾	¾	¾	1¼	1¼	1¼	1½	1½	1½	2	2	2½	CB
CD	½	½	½	¾	¾	¾	1	1	1	1-3/8	1¾	2	CD
CW	½	½	½	5/8	5/8	5/8	¾	¾	¾	1	1¼	1¼	CW
DD	¼-28	5/16-24	5/16-24	3/8-24	3/8-24	½-20	½-20	5/8-18	5/8-18	¾-16	¾-16	7/8-14	DD
E	2	2½	3	3¾	4½	5½	6½	7½	8½	10-5/8	12¾	14¾	E
EB	—	—	—	—	—	—	—	5/8	5/8	¾	¾	7/8	EB
EE	3/8	3/8	3/8	½	½	½	¾	¾	¾	1	1	1¼	EE
F	3/8	3/8	3/8	5/8	5/8	5/8	¾	¾	¾	¾	¾	¾	F
FB	¾	5/16	5/16	3/8	3/8	½	½	—	—	—	—	—	FB
G	1½	1½	1½	1¾	1¾	1¾	2	2	2	2½	2½	2¾	G
H	1-1/8	1-1/8	1¼	1¼	1¼	1½	1½	1-5/8	1-5/8	2-1/8	2-5/8	3-1/8	H
J	1	1	1	1¼	1¼	1¼	1½	1½	1½	2	2	2¼	J
J*	1	1	1	1¼	1¼	1¼	1½	1½	1½	2	2	2¼	J
K	¾	5/16	5/16	3/8	3/8	7/16	7/16	9/16	9/16	11/16	11/16	13/16	K
KB	3/16	5/16	5/16	¼	¼	½	3/8	—	—	—	—	—	KB
L	¾	¾	¾	1¼	1¼	1¼	1½	1½	1½	2-1/8	2½	2½	L
LD	4-7/8	4-7/8	5	6	6	6¾	7	5-5/8	5-5/8	6-5/8	7-1/8	8-5/8	LD
LR	11/16	11/16	11/16	1-1/8	1-1/8	1-1/8	1-3/8	1-3/8	1-3/8	1-7/8	2	2¼	LR
NR	5/8	5/8	5/8	15/16	15/16	15/16	1-3/16	1-3/16	1-3/16	1-3/8	1¾	2	NR
NT	¼-20	5/16-18	3/8-16	½-13	½-13	5/8-11	¾-10	¾-10	¾-10	1-8	1-8	1¼-7	NT
O	2-3/8	3	3-5/8	4¾	5½	6¾	8	9¾	10¾	12¾	15	17	O
P	2¼	2¾	2-3/8	2-5/8	2-5/8	2-7/8	3-1/8	3¾	3¾	4-1/8	4-5/8	5½	P
R	1.43	1.84	2.19	2.76	3.32	4.10	4.88	5.73	6.44	7.92	9.40	10.90	R
SB	3/8	3/8	3/8	½	½	¾	¾	¾	¾	1	1	1¼	SB
SN	2¼	2¼	2-3/8	2-5/8	2-5/8	2-7/8	3-1/8	3¾	3¾	4-1/8	4-5/8	5½	SN
SS	2-7/8	2-7/8	3	3¾	3¾	3-1/8	3-5/8	3¾	3¾	4-5/8	5-1/8	5-7/8	SS
ST	½	½	½	¾	¾	1	1	1	1	1¼	1¼	1½	ST
SU	15/16	15/16	15/16	1¼	1¼	1-9/16	1-9/16	1-9/16	1-9/16	2	2	2½	SU
SW	3/8	3/8	3/8	½	½	11/16	11/16	11/16	11/16	7/8	7/8	1-1/8	SW
SX	3/8	3/8	3/8	½	½	11/16	11/16	11/16	11/16	7/8	7/8	1-1/8	SX
SY	3/8	3/8	3/8	½	½	11/16	11/16	11/16	11/16	7/8	7/8	1-1/8	SY
TD <sup>0.002</sup>	1.000	1.000	1.000	1.000	1.000	1.000	1.375	1.375	1.375	1.750	1.750	2.000	TD <sup>0.002</sup>
TE	—	—	—	—	—	—	—	6.75	7.57	9.40	11.10	12.87	TE
TF	2¼	3-3/8	3-7/8	4-11/16	5-7/16	6-5/8	7-5/8	—	—	—	—	—	TF
TL	1	1	1	1	1	1	1-3/8	1-3/8	1-3/8	1¾	1¾	2	TL
TM <sup>0.002</sup>	3.495	3.995	4.495	5.245	5.995	6.995	8.495	9.495	10.495	13.120	15.245	17.745	TM <sup>0.002</sup>
TN	5/8	7/8	1¼	1½	2-1/16	2-11/16	3¾	3-7/8	4½	5½	7¼	8-3/8	TN
TS	2¼	3¼	3¾	4¾	5½	6-7/8	7-7/8	8-7/8	9-7/8	12-3/8	14½	17	TS
TT	1-1/8	1-1/8	1-1/8	1¼	1¼	1¼	1½	2	2	2¼	2½	3	TT
U	1½	1½	1½	1½	1½	1½	2	2¼	2½	3	3	3½	U
UF	3-3/8	4-1/8	4-5/8	5½	6¾	7-5/8	8-5/8	—	—	—	—	—	UF
UM	5½	6	6¾	7¾	8	9	11¼	12¾	13¾	16-5/8	18¾	21¾	UM
US	3½	4	4¾	5¾	6¾	8¾	9¾	10¾	11¾	14-1/8	16¾	19¾	US
UT	4	4½	5	5¾	6¾	7½	9¾	10¾	11¾	14-1/8	16¾	18¾	UT
W	5/8	5/8	5/8	¾	¾	¾	7/8	1-5/8†	1-5/8†	1-7/8†	2†	2¼†	W
WF	1	1	1	1-3/8	1-3/8	1-3/8	1-5/8	—	—	—	—	—	WF
XC	5-3/8	5-3/8	5½	6-7/8	6-7/8	7-1/8	8-1/8	8¾	8¾	10-3/8	11-1/8	12-7/8	XC
XF	4-5/8	4-5/8	4¾	5-5/8	5-5/8	5-7/8	6-5/8	—	—	—	—	—	XF
XG	1-15/16	1-15/16	1-15/16	2-7/16	2-7/16	2-7/16	2-13/16	2-13/16	2-13/16	3-1/8	3¾	3-13/16	XG
*XI <sub>(Min)</sub>	3-1/16	3-1/16	3-1/16	3¾	3¾	3¾	4-3/8	4-5/8	4-5/8	5¾	5½	6½	*XI <sub>(Min)</sub>
XJ	4-3/16	4-3/16	4-5/16	5-1/16	5-1/16	5-5/16	5-15/16	6-1/16	6-1/16	7¾	7-7/8	9-5/16	XJ
XK	—	—	—	—	—	—	—	5¾	5¾	6¾	6-7/8	8-1/8	XK
XS	1-3/8	1-3/8	1-3/8	1-7/8	1-7/8	2-1/16	2-5/16	2-5/16	2-5/16	2¾	2-7/8	3-3/8	XS
XT	1-15/16	1-15/16	1-15/16	2-7/16	2-7/16	2-7/16	2-13/16	2-13/16	2-13/16	3-1/8	3¾	3-13/16	XT
Y	1-15/16	1-15/16	1-15/16	2-7/16	2-7/16	2-7/16	2-13/16	2-13/16	2-13/16	3-1/8	3¾	3-13/16	Y
ZB	4-5/8	4-5/8	4¾	5-5/8	5-5/8	5-7/8	6-5/8	6¾	6¾	8¾	8-7/8	10-3/8	ZB
ZF	5	5	5-1/8	6¾	6¾	6¾	7-3/8	—	—	—	—	—	ZF
ZJ	—	—	—	—	—	—	—	6¾	6¾	8¾	8-7/8	10-3/8	ZJ
ZL	5½	5½	5-5/8	6¾	6¾	7	7-7/8	7¾	7¾	8¾	9-1/8	10-7/8	ZL
ZM	6-1/8	6-1/8	6¾	7½	7½	7¾	8¾	8-7/8	8-7/8	10-3/8	11-1/8	13-1/8	ZM

\*Customer to Specify

## † LARGE BORE BUSHING RETAINER CONFIGURATION

Typical For  
ALL Mounting  
Styles on  
7, 8, 10, 12, 14"  
Bores.

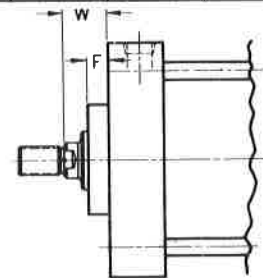
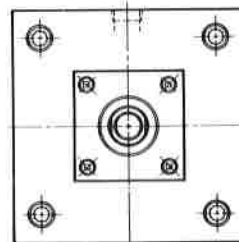

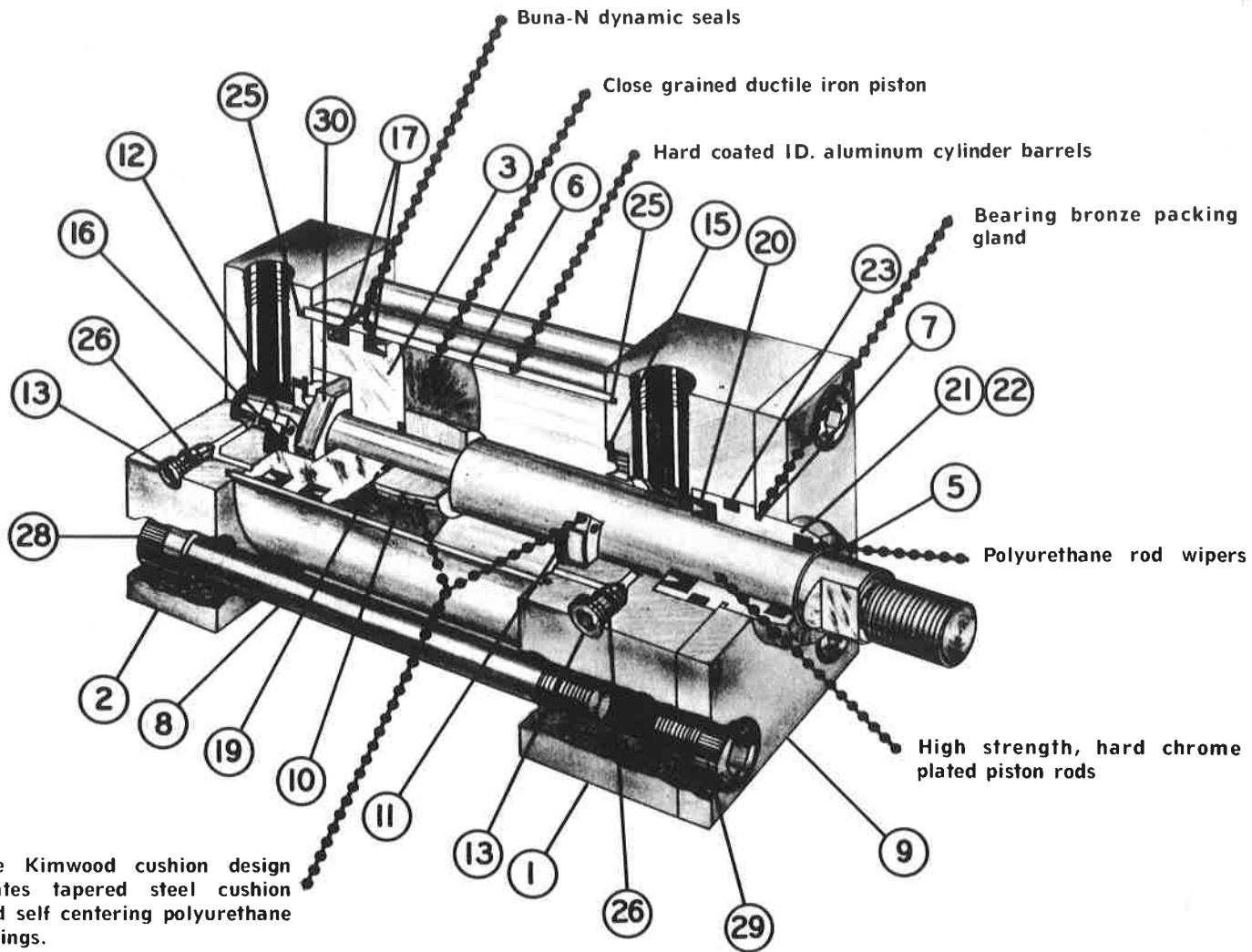

## PARTS LIST

ITEM NO.	PART NAME	ITEM NO.	PART NAME
1	HEAD	19	PISTON TO ROD SEAL
2	CAP	20	ROD SEAL
3	PISTON (Cup Type)	21	ROD WIPER (Polyurethane)
4	PISTON (Ring Type) (Not Shown)	22	ROD SCRAPER (Metallic) Optional
5	PISTON ROD	23	ROD GLAND O.D. SEAL
6	BARREL	24	
7	ROD GLAND	25	BARREL SEAL
8	TIE BOLTS	26	NEEDLE VALVE SEAL OR BALL PLUG SEAL
9	RETAINER PLATE	27	CUSHION PLUG SEAL (Not Shown)
10	CUSHION PLUG	28	TIE BOLT NUTS
11	HEAD END CUSHION RING ASSY.	29	RETAINER BOLTS
12	CAP END CUSHION RING ASSY.	30	PISTON NUT
13	NEEDLE VALVE	31	AIR BLEED SCREW (Not Shown)
14	BALL PLUG (Not Shown)	32	AIR BLEED SCREW SEAL (Not Shown)
15	HEAD END CUSHION RING RETAINER	33	
16	CAP END CUSHION RING RETAINER	34	
17	PISTON CUPS	35	
18	PISTON RINGS (Cast Iron) (Not Shown)	36	

# INSTALLATION AND MAINTENANCE

Maximum service life for air and hydraulic cylinders is dependent upon using correct application techniques, proper installation and maintenance.

The instructions on Pages 2 & 3 will be helpful in selecting the right cylinder for the application and the instructions below should be followed during installation and maintenance.

## INSTALLATION

### Air

Clean filtered and lubricated air is a must for obtaining a full life from an air cylinder. Lubricants with aine points above 225° F are recommended.

### Hydraulic

Standard Kimwood hydraulic cylinders should be installed only in systems using a good grade of petroleum based hydraulic oil. Oils with aine points above 225° F are recommended. When use of special oils and fire resistant fluids are to be used, consult the factory. All oil used in these systems should be filtered through a 25 micron filter prior to use and circulated through this micron filter continuously.

### Temperatures

Normal operating temperature for Kimwood hydraulic cylinders should not exceed 212° F. For high temperature service, special seals are available on request.

### Rigid Mountings

The major percentage of premature cylinder failures are due to misalignment caused by side thrust. This side thrust is best

controlled by proper mounting techniques. Most alignment problems arise with rigid type mountings such as mounting styles A, B, C, E, F, G, H, N, O and P. Within these mounting styles, the cylinder body is held rigid and the rod end must be aligned to the body in all positions of its travel.

The correct alignment can normally be achieved by leaving the mounting bolts loose and working the cylinder through its stroke manually. Shims under the mounts may be necessary on some mounting styles but should be avoided when possible.

Once the cylinder is properly aligned we recommend keying or the use of dowels to maintain alignment and take shear loads off the mounting bolts. On all side lug mountings, ample space is available for dowel pins. Flange mounting plates also have ample space for pinning. When keying, always place the key in front of or behind the head or cap to take thrust loads. Fasten the key to the machine member when possible, *not* to the cylinder. Integral keys are available on mounting styles A, B & C upon request. Keying is always recommended on the side tapped mounting Style "C". The key should be adequate to take all of the shear load off the mounting bolts. **CAUTION:** Key one end only, never both.

## MAINTENANCE

Replacing: Rod Gland — Item # 7

Rod Seal — Item #20

Rod Wiper — Item #21 or 22

Gland O.D. Seal — Item #23 & 24

1. Extend piston rod, Item #5, 1/4 of stroke.
2. Remove pressure from system.
3. Support rod to prevent damage when rod gland is removed. (Support cylinder also on pivot mounted applications.)
4. Remove rod end accessories.
5. Remove burrs from rod flats.
6. Remove retainer bolts, Item #29.
7. Remove retainer plate, Item #9.
8. Remove rod gland by prying with screwdriver in pry-out groove.
9. Clean all parts.
10. Lubricate all parts to be replaced with oil compatible with the system.
11. Push or tap rod gland back into head being careful not to damage rod seals.
12. Replace retainer plate and retainer bolts.
13. Torque retainer bolts per Table 5 below.

Replacing: Piston Seals — Item #17 or 18

Barrel Seals — Item #25

Piston I.D. Seals — Item #19

Cushion Plug Seals — Item #27

1. Remove complete cylinder from the mounting member and thoroughly clean with a suitable solvent. Disassemble the cylinder on a clean working surface.
2. Remove rod gland and seals, Items 7, 20, 21 or 22, 23 & 24. See Replacing rod gland instructions above — 1 thru 10.

3. Remove tie bolt nuts, Item #28.
4. Remove cap, Item #2.
5. Remove barrel, Item #6; from head, Item #1; with piston, Item #3; and piston rod, Item #5; inside. Use care in preventing the rod from being damaged during removal.
6. Pull piston rod assembly from barrel.
7. Remove any damaged parts.
8. Do not remove piston from piston rod unless parts are damaged or definite leakage is occurring by the piston.
9. If piston is removed from the piston rod, reassemble using piston nut torque values shown below. (Table 6)
10. Clean all parts thoroughly.
11. Lubricate replacement parts before assembly with oil compatible with system.
12. When replacing piston cups, Item #17, place the cup in the groove nearest the rod end with the cupped side facing the rod end. Lubricate lightly and push piston and rod assembly into the barrel, holding on to the piston rod. Push the piston through the barrel until the empty groove is exposed on the opposite end. Place the cup in the exposed groove with cupped side facing away from the rod end. Pull the rod and the piston into the barrel.
13. When replacing piston ring seals, always stagger the joints.
14. Reassemble the barrel to the head.
15. Replace tie rod nuts.
16. Replace cap.
17. Torque tie rods per Table 7 below by tightening each one a little at a time, alternating with opposite tie rods until recommended torque is reached.
18. Replace rod gland as outlined above in rod gland replacement instruction #11, 12 and 13.

RETAINER BOLT TORQUES

BORE SIZE	THREAD SIZE	TORQUE FT. LBS.
1 1/2	1/4-28	8
2	5/16-24	15
2 1/2	5/16-24	15
3 1/4	3/8-24	34
4	3/8-24	34
5	1/2-20	62
6	1/2-20	62
7	*	*
8	*	*
10	*	*
12	*	*
14	*	*

TABLE NO. 5

\*Consult Factory

PISTON NUT TORQUES

BORE SIZE	THREAD SIZE	TORQUE FT. LBS.
1 1/2	7/16-20	55
2	7/16-20	55
2 1/2	7/16-20	55
3 1/4	3/4-16	185
4	3/4-16	185
5	3/4-16	185
6	1-14	375
7	1-14	375
8	1-14	375
10	1 1/4-12	690
12	1 1/2-12	995
14	1 7/8-12	1415

TABLE NO. 6

TIE ROD TORQUES

BORE SIZE	THREAD SIZE	TORQUE FT. LBS.	ELONGATION IN 36"
1 1/2	1/4-28	8	1/16"
2	5/16-24	15	1/16"
2 1/2	5/16-24	15	1/16"
3 1/4	3/8-24	34	5/64"
4	3/8-24	34	5/64"
5	1/2-20	62	1/16"
6	1/2-20	62	1/16"
7	3/8-18	110	1/16"
8	5/8-18	110	1/16"
10	3/4-16	185	1/16"
12	3/4-16	230	5/64"
14	7/8-14	356	5/64"

TABLE NO. 7

# ORDERING INFORMATION

All information listed below must be specified on order. Complete and accurate information will insure prompt deliveries. On replacement parts, please order by parts list item number and part name. (See page 6) Also include cylinder model no.

- |                         |  |  |
|-------------------------|--|--|
| 1. Quantity             | 8. Rod size if other than std.                               | 14. Type of fluid                                  |
| 2. Bore                 | 9. Rod end if other than std.                                | 15. Pressure maximum and operating                 |
| 3. Stroke               | 10. Rod extension if required                                | 16. Temperature range                              |
| 4. Series               | 11. Port position if other than std.                         | 17. XI dimension on all trunnion mounted cylinders |
| 5. Mounting style       | 12. Port size if other than std.                             | 18. Air bleed if required and positions            |
| 6. Cushions if required | 13. Cushion adjustment and check position if other than std. | 19. Delivery requirements                          |
| 7. Stop tube required   |  |  |

## CYLINDER MODEL NUMBERING

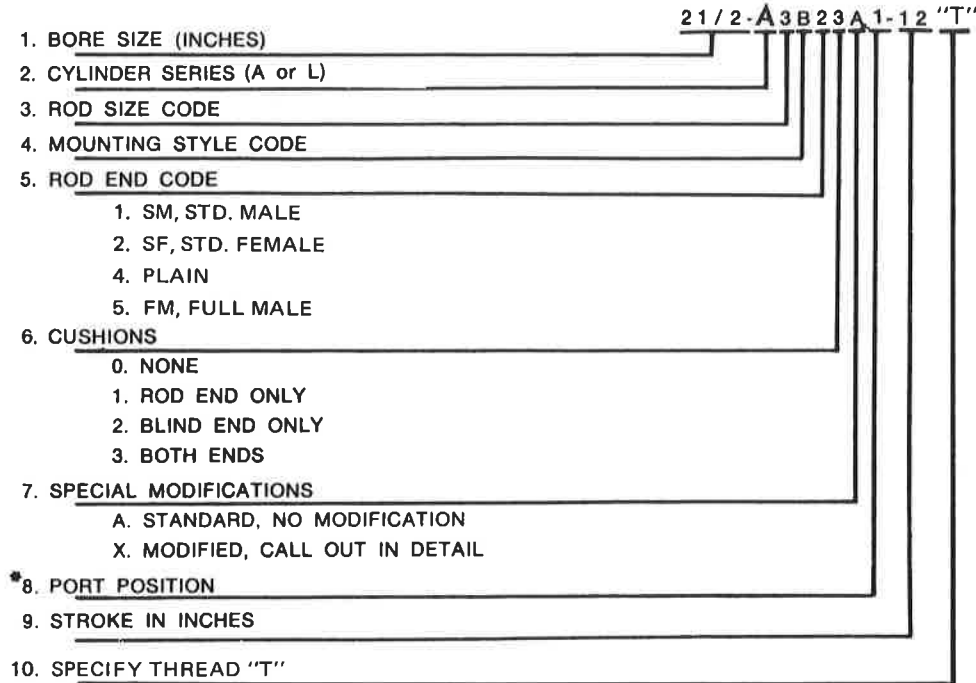

\*Port positions are shown on dimensional drawings in clockwise fashion (1) through (4). View from rod end.

1. Cushion adjustment position is indicated by © on Dimensional Drawings. Please state on order if position is to be changed. Caution: Check mountings to avoid interference.

2. Cushion check plug position is indicated by ⊙ on Dimensional Drawings. The cushion check is used only when cushions are specified in over-sized rod cylinders.

## REPAIR KIT ORDERING INFORMATION

ORDER SEAL & REPAIR KITS BY NUMBER DEVELOPED BELOW

### I. ROD SEAL KITS

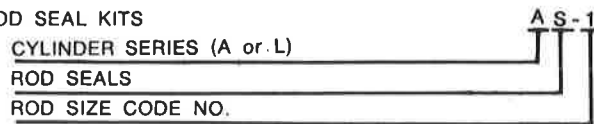

PARTS INCLUDED:

- ITEM NO. 20 ROD SEAL
- ITEM NO. 21 ROD WIPER
- ITEM NO. 23 PACKING GLAND "O" RING
- ITEM NO. 24 PACKING GLAND "O" RING BACK-UP RING

### II. ROD GLAND KITS

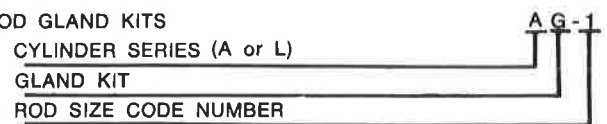

PARTS INCLUDED:

- ITEM NO. 7 ROD GLAND
- ITEM NO. 20 ROD SEAL
- ITEM NO. 21 ROD WIPER
- ITEM NO. 23 PACKING GLAND "O" RING
- ITEM NO. 24 PACKING GLAND "O" RING BACK-UP RING

### III. PISTON SEAL KITS

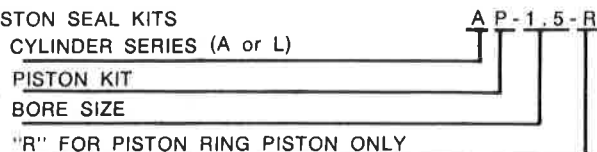

PARTS INCLUDED:

- ITEM NO. 17 or 18 PISTON CUPS OR PISTON RINGS
- ITEM NO. 19 PISTON I.D. "O" RING
- ITEM NO. 25 BARREL "O" RINGS
- ITEM NO. 27 CHOKE PLUG "O" RING

### IV. COMPLETE SEAL KITS

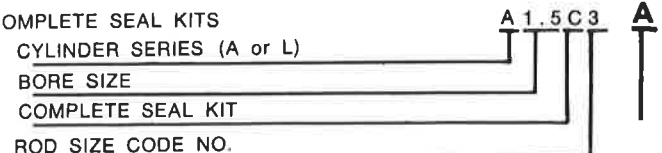

PARTS INCLUDED:

- GLAND KIT AND PISTON KIT COMBINED
- CUSHIONS (A) None (B) Rod End (C) Blind End (D) Both Ends